

# PALLET JACK SCALE



NTEP CC 18-074



EASY TO USE  
INDICATOR WITH  
BUILT IN PRINTER



Carbon Steel



Stainless Steel



Having a scale built into your pallet jack will increase efficiency and productivity by eliminating the need to place your pallet on a scale to weigh, saving time and money. Tufner's Pallet Jacks are rugged, precise, efficient and cost effective. They are the ideal solution for mobile weighing.

## FEATURES

- Unique and user friendly design
- Reinforced construction for heavy and long use
- Effortless steering on flat or uneven surfaces
- NTEP approved 3,000 x 1 lb and 5,000 x 2 lbs
- Super low 2.9" profile with tapered fronts for easy pallet entrance
- Ergonomic full function pump handle for easy lifting, steering and weighing
- 120V rechargeable battery (operates up to 60 hours)
- Includes a built-in LCD display and optional built-in thermal printer (P model)
- Units: lb and kg switchable
- Single wheel design helps prevent jack from getting stuck or breaking your pallet compared to double wheeled designs
- The Small raised wheel on the inside assists the user when rolling onto pallet

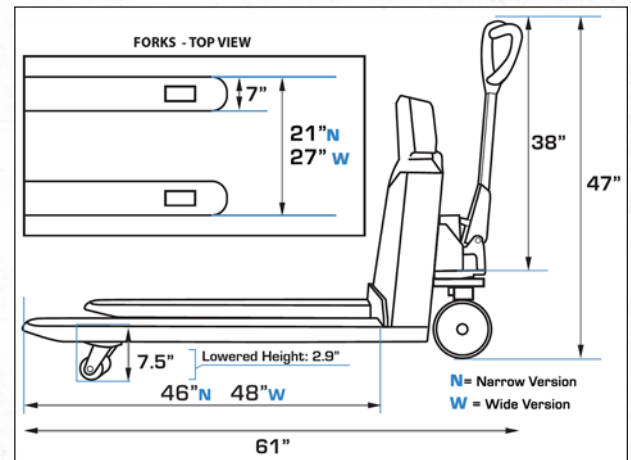

MODEL	MATERIAL	CAPACITY	FORK SIZE	PRINTER	SHIP WT.
T918-N-5	Carbon Steel	5,000 lb x 1 lb	46" L x 21" W x 2.9" H	No	350 lbs
T918-N-P-5	Carbon Steel	5,000 lb x 1 lb	46" L x 27" W x 2.9" H	Yes	360 lbs
T918-W-5	Carbon Steel	5,000 lb x 1 lb	48" L x 27" W x 2.9" H	No	350 lbs
T918-W-P-5	Carbon Steel	5,000 lb x 1 lb	48" L x 27" W x 2.9" H	Yes	360 lbs
T918-SS-3.3	Stainless Steel	3,300 lb x 1 lb	48" L x 27" W x 2.9" H	No	350 lbs
T918-SS-P-3.3	Stainless Steel	3,300 lb x 1 lb	48" L x 27" W x 2.9" H	Yes	360 lbs

NTEP CC 18-074 Class III 3,000 d - NTEP 5,000 lb x 2 lb & 3,000 lb x 1 lb

# MOTORIZED PALLET JACK SCALE

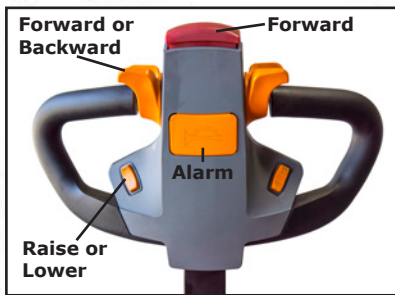

No pumping needed, simply press a button to lift or lower

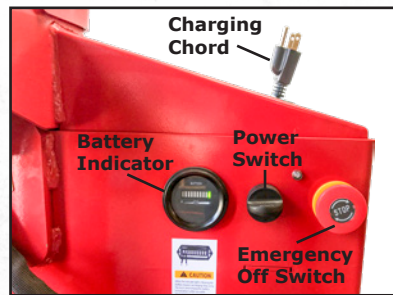

Large battery indicator and 9ft charging cord



User friendly back-lit indicator with optional printer

Tufner's motorized pallet jack scales make it easy to lift, transport and weigh pallets without any effort. Simply press the buttons on the handle and let the machine do all the work, all you have to do is steer.

## FEATURES

- Unique and user friendly design
- Reinforced construction for heavy and long use
- Effortless steering on flat or uneven surfaces
- Built-in NTEP approved load cells
- Ultra low 2.75" profile with tapered fronts for easy pallet entrance
- Ergonomic, no pumping needed handle, for easy lifting, steering and weighing
- 120V rechargeable indicator battery (up to 60 hours)
- Includes a built-in LCD display and optional built-in thermal printer (P model)
- Units: lb and kg switchable
- Single wheel design helps prevent jack from getting stuck or breaking your pallet compared to double wheeled designs
- The Small raised wheel on the inside assists the user when rolling onto pallet

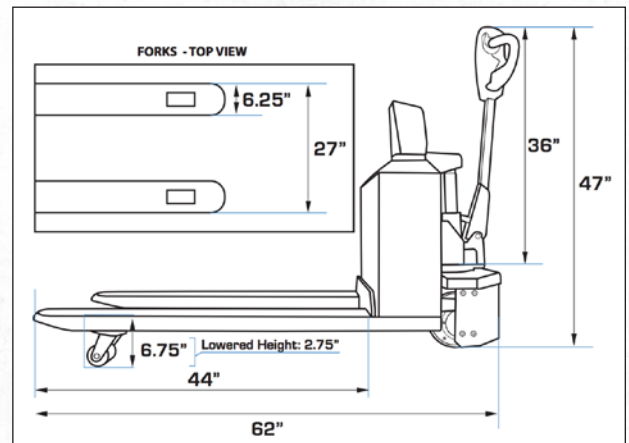

MODEL	MATERIAL	CAPACITY	FORK SIZE	PRINTER	SHIP WT.
T918M-3300	Carbon Steel	3,300 x 1lb	44"(L) x 27"(W)	No	625 lbs
T918M-P-3300	Carbon Steel	3,300 x 1lb	44"(L) x 27"(W)	Yes	625 lbs