



TUFNER WEIGHING SYSTEMS

9030 Bridgeport Place, Rancho Cucamonga, CA 91730

Main: 800-810-2965 Fax: 888-502-8997

8000 Repel Digital Weight Indicator

Installer's Manual



V1.6

Table of Contents

1. TABLE OF CONTENTS.....	2
1.1 Scope of 8000 REPEL.....	2
1.2 Installation of 8000 REPEL digital indicator.....	3
1.3 RS-232 Connections (COM1).....	4
1.4 Power Connections (AC version).....	4
1.5 Power Connections (Optional Rechargeable Battery version).....	4
.....	5
1.6 USB Port	5
1.7 Installation of TI-500 RFTM remote wireless A/D Module.....	5
1.8 Installation of LCT-1 remote wireless digital junction box	6
1.9 Getting Started – Cabled Systems	8
1.10 Getting Started – Wireless Systems.....	8
2 SYSTEM CONFIGURATION.....	9
2.1 Configuration Menus.....	9
2.2 Entering the Setup (“F”) Configuration Menu	10
2.3 Setup (“F”) Menu Descriptions.....	10
2.4 Entering the User/COM1 (“A1”) Menu	16
2.5 User/COM1 (“A1”) Menu Descriptions.....	17
2.6 Setting system time and date (A1-20)	19
2.7 Diagnostics (A1-24).....	21
2.8 Entering the COM2 (“A2”) Menu.....	21
2.9 COM2 (“A2”) Menu Descriptions	22
3 SYSTEM CALIBRATION.....	23
3.1 Calibration Overview.....	23
3.2 Digital Zero/Span Calibration (F16 and F17).....	23
3.3 Key-In Zero Calibration Value (F19)	25
3.4 Key-In Span Calibration Value (F20).....	25
4 SERIAL PORT INFO	26
4.1 Serial Port Modes.....	26
4.2 Output Strings	27

NOTE: A wireless LCT-1 junction box can be substituted for the RFTM in the above diagram.

Our products currently use reliable and popular Bluetooth® wireless technology. This manual covers installation, configuration and calibration of the RF scale system. For operation and troubleshooting, please refer to the separate user's guide.

1.2 Installation of 8000 REPEL digital indicator

Find a suitable location for the indicator and use the included bracket to mount the unit to a wall or table. Use this handy guide for mounting the bracket to a wall or table:

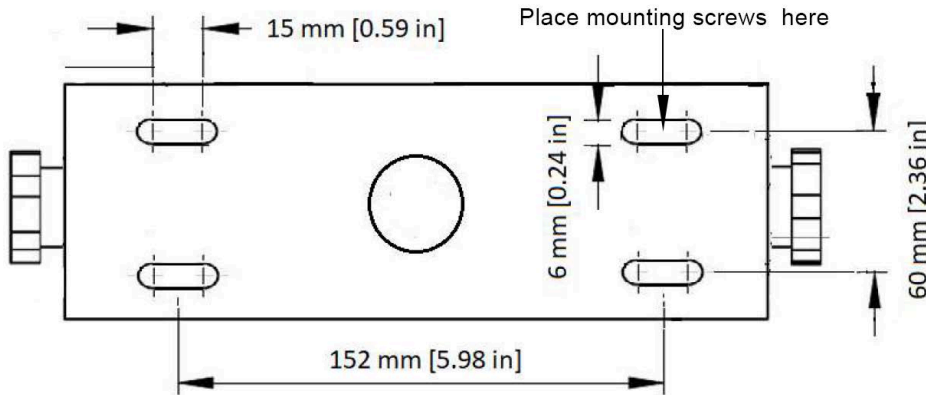

CONNECTIONS

The rear cover must first be removed to make the appropriate connections to the weigh platform, etc. To remove the rear cover, simply remove the screws that secure it to the enclosure and set aside.

Caution! Disconnect power source from indicator prior to removing rear cover.

Caution! Disconnect leads from rechargeable battery (if installed) to avoid shorts!

Load Cell Connections: Connect your shielded load cell cable to terminal block J1 using the table below. Pin 1 is on the right.

TIP: You should have the color codes handy for your load cell / junction box / weighing platform before doing so.

Load Cell Terminal Block J1

Pin No.	Marking	Function
3	GND	Shield
4	E+	+ Excitation
5	SE+	+ Sense
6	S+	+ Signal

7	S-	- Signal
8	SE-	- Sense
9	E-	- Excitation

NOTE1: Use F11 to configure for 4-wire or 6-wire load cells

NOTE2: Pins 1 and 2 are for DC power input (V+ and V– respectively) ...

1.3 RS-232 Connections (COM1)

The indicator ships with a “piggyback” RS-232 communication board plugged into socket U9 (COM1). This port is configured via the User/COM1 (“A1”) menu. Connect your RS-232 serial communications cable to said “piggyback” board using the table below. Pin 1 is on the left.



COM1 RS-232 Terminal Block (J6)

Pin No.	Function
1	Receive Data
2	Transmit Data
3	Signal Ground

1.4 Power Connections (AC version)

The 8000 REPEL indicator ships with a pre-installed AC line cord. It has been pre-wired to Terminal Block J1 at the factory. Simply plug the unit into a standard wall outlet.

1.5 Power Connections (Optional Rechargeable Battery version)

This version ships with a pre-installed power connector and an external battery charger. Simply link the two up, and plug the battery charger into a suitable AC wall outlet. Note that the external battery charger is rated for IP54 only.



1.6 USB Port

The external USB port is used for updating of the firmware only. Consult factory for use.

1.7 Installation of TI-500 RFTM remote wireless A/D Module

Physical installation

The remote wireless A/D module is designed to fit into a pre-defined opening:

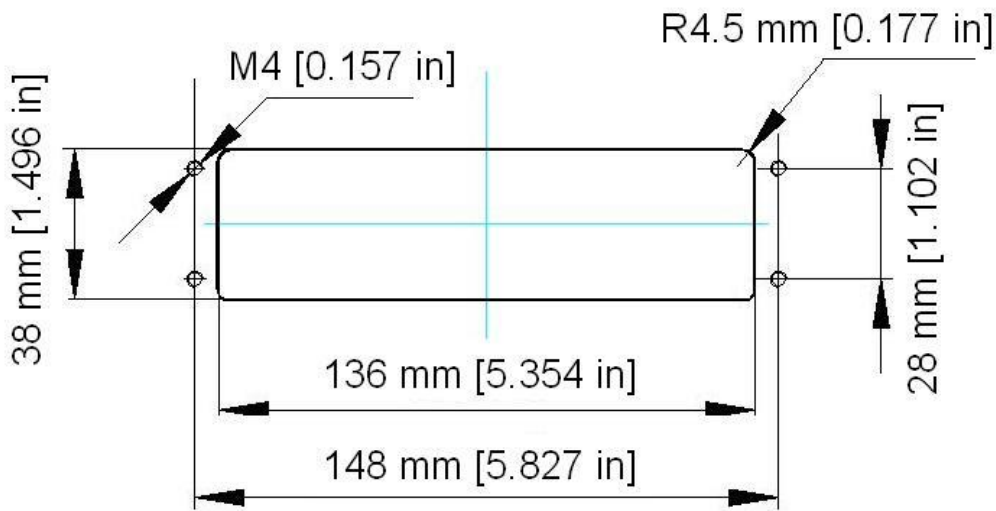

An optional mounting bracket is also available.

Electrical Connections

The TI-500 RFTM module requires an external 6VDC power supply. Single channel units require about 60 mA of current to drive four 350-ohm load cells (20 mA plus 10 mA per load cell). Dual channel units require about 100 mA of current to drive eight 350-ohm load cells.

The TI-500 RFTM module will operate normally down to approximately 4 VDC whereupon it will indicate a low battery condition.

The power leads are pre-wired to the inside of the TI-500 RFTM. The red lead goes to the positive DC terminal while the black lead goes to the negative DC terminal.

The TI-500 RFTM module also has at least one load cell input terminal or wiring harness. Each terminal or harness can drive up to four 350-ohm load cells. The terminals are spring loaded; to open, use a small screwdriver to press down on the orange tab. The harnesses should be spliced to the load cell or j-box using the supplied butt splices.

Load Cell Input Terminal

Marking	Wire Name		Marking	Wire Name
S-	- Signal		E-	- Excitation
S+	+ Signal		E+	+ Excitation

NOTE: On dual RF A/D modules, each load cell terminal is marked 1-4, e.g. L/C3.

Load Cell Input Harness

Wire Color	Wire Name		Wire Color	Wire Name
White	- Signal		Black	- Excitation
Green	+ Signal		Red	+ Excitation

1.8 Installation of LCT-1 remote wireless digital junction box

Physical installation

Find a suitable location for the digital junction box and use the mounting tabs to mount the unit to a wall or table. The junction box may be mounted vertically or horizontally. Use this handy guide for mounting the box to a wall or table:

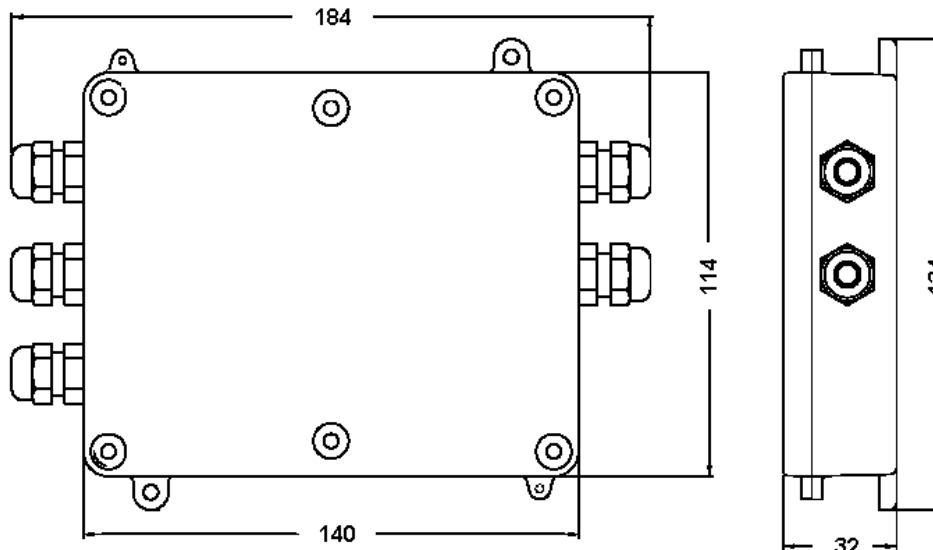

Electrical Connections

The top cover must first be removed to make the appropriate connections to the weigh platform. To remove the top cover, simply remove the six (6) screws that secure it to the enclosure and set aside.

Caution! Disconnect power source from junction box prior to removing top cover.

Note: If the optional control panel was ordered, you need not make connections to the LCT-1 for power supply, serial device or on/off control

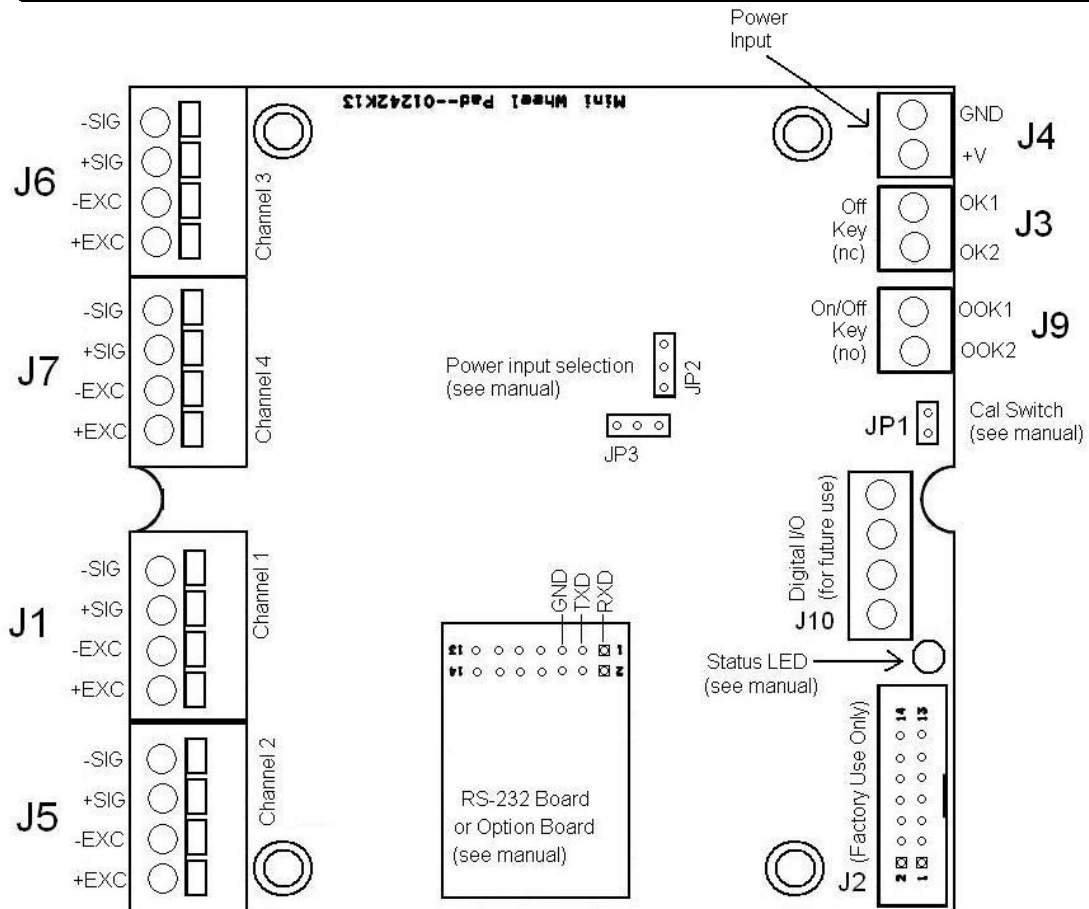

Connecting your load cell(s)

The LCT-1 contains four connection terminals on the main board – one for each load cell:

1. LC1: J1
2. LC2: J5
3. LC3: J6
4. LC4: J7

Connect your load cell cable (not included) to the appropriate terminal on the main board.

Caution! Strip each load cell wire back 10 mm and tin before inserting into the spring-loaded terminals.

Load Cell Terminals (J1, J5, J6 and J7)

Label	Function
S-	- Signal
S+	+ Signal
E-	- Excitation
E+	+ Excitation

Caution! If connecting less than four load cells to the LCT-1, then the S+ and S- terminals **must be shunted with a jumper wire** on each unused load cell input terminal

1.9 Getting Started – Cabled Systems

1. Press and hold the ON key on the digital indicator unit for two seconds. After a brief initialization period, the scale will revert to a zero ("0") weight display.

Your digital indicator is now ready for configuration and system calibration.

1.10 Getting Started – Wireless Systems

1. Switch on the TI-500 RFTM remote wireless A/D module(s) by pressing the BLUE button once. The blue LED will turn solid for a few seconds and then start to flash.
2. Next press and hold the ON key on the digital indicator unit for two seconds. After a brief initialization period, the scale will revert to a zero ("0") weight display.

Your wireless digital indicator is now ready for configuration and system calibration.

2 SYSTEM CONFIGURATION

2.1 Configuration Menus

The 8000 REPEL digital indicator contains three menus to configure the scale system:

Setup ("F") Menu – Configures all scale-related parameters including calibration procedures.

User1 ("A1") Menu – Configures COM1 communication parameters and other misc. parameters, e.g. automatic turn off and hold mode.

User2 ("A2") Menu – Configures COM2 communication parameters.

The configuration menus are laid out in the following vertical arrangement:

- Top [Menu selection] level
- Parameter level
- Selection level (or function level, e.g. span calibration)

Please review the following chart to get a feel for how to navigate among the various menus and parameters.

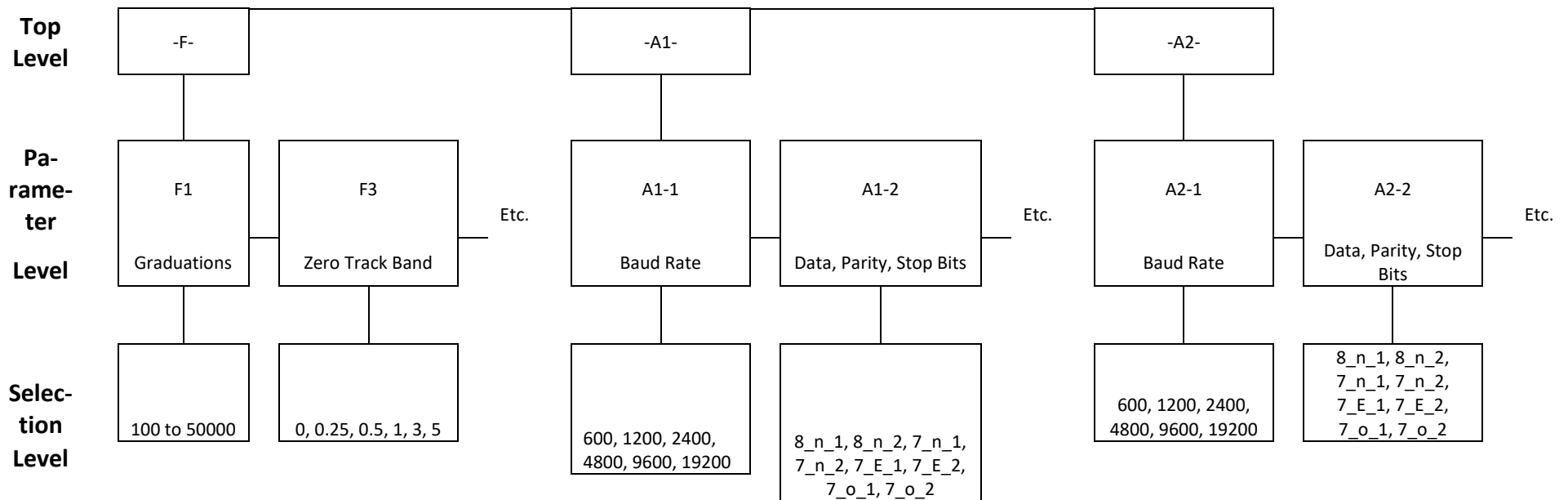

2.2 Entering the Setup (“F”) Configuration Menu

To access this menu, please follow these directions:

1. Press and hold the MENU/OFF key to switch off the digital indicator.
2. Press and hold the ON key until the digital indicator beeps and starts to boot up.
3. During the countdown phase (“555555, 444444”, etc.) press and hold the MENU/OFF key until the “Set?” message is displayed.
4. Press the NET/GROSS button while “Set?” is being displayed. The digital indicator displays “- F -”.
5. Scroll down using the ZERO (down) key to reach the parameter level. The scale shows “F 1”.
6. Move from one “F” menu parameter to the next by using the TARE (left) or PRINT (right) keys. For example, to go from F1 to F2, press the PRINT key. To go from F2 back to F1, press the TARE key.
7. Once you have arrived at the proper “F” menu parameter, e.g. “F 1”, press the ZERO (down) key once to arrive at the selection level. The scale displays the current parameter setting.
8. If there is a selection list, scroll thru the available parameter settings, use the TARE (left) or PRINT (right) keys. Otherwise, use the arrow keys to adjust the displayed value to the new value.
9. Once the setting you want is displayed on the screen, press the NET/GROSS (set) key to save this value and revert up to the parameter level, e.g. “F 1”.
NOTE: If you see a “CAL-Err” message, the parameter changes were not saved. To allow changes, you must open the unit and shunt jumper JP1.

2.3 Setup (“F”) Menu Descriptions

This section provides more detailed descriptions of the selections found in the Setup Menu Chart. Factory-set defaults are shown in **bold** with a checkmark; (✓).

CODE/NAME	DESCRIPTION	SELECTION LIST
F1 Graduations	Specifies number of full-scale graduations, i.e. capacity / division. Value should be consistent with legal regulations and environmental limits on the useful system resolution. Pressing the ZERO key to scroll down one level begins the sequence.	Key-in 100 - 100000 10000 ✓

F2 Sampling Rate	Sets the sampling rate in Hertz (measurements per second). Use 10 Hz for most applications or 80 Hz for extra fast response time NOTE: This menu is not applicable to wireless systems	Key-in 10 – 960 20 ✓
F3 Zero Track Band	Selects the range within which the scale will automatically zero. Note that the scale must be in standstill to automatically zero. Selections are in display divisions (d).	0 (Off) 0.5 ✓ 1 3 5

CODE/NAME	DESCRIPTION	SELECTION LIST
F4 Zero Range	Selects the range within which the scale will accept a front panel ZERO command. Note that the scale must be in standstill to automatically zero. Selections are in display % of full scale. Pressing the ZERO key to scroll down one level begins the sequence.	100 ✓ 1.9 2 20
F5 Motion Band	Sets the level at which motion is detected. If motion is not detected, the scale can process a Print or Zero command. Maximum value varies depending on local regulations. Expressed as scale divisions per second (d/s). Pressing the ZERO key to scroll down one level begins the sequence	Key-in 0.0 – 32.0 1.0 ✓
F6 Digital Filter	Averages weight readings to produce higher stability. Choose the speed that works best for your application. "AUto" = Automatic, Flr = FIR (finite impulse response), "Avg-xx" = Averaging Filter	Auto ✓ Flr 01, 04, 08, 16, 24, 32, 40, 48, 56, 64
F7 Overload Limit	Selects the desired formula which determines the point at which the indicator shows overload. All selections are based on the primary unit selected in F8. "FS" = Full scale capacity.	FS FS + 2% ✓ FS + 5% FS + 1d FS + 9d
F8 Calib. Unit	Selects the primary base unit to be used in the calibration process and the default unit for normal operation. "1" = primary unit is lb "2" = primary unit is in kg	1 ✓ 2
F9 Display Divisions	Determines the desired weight increments. Value should be consistent with legal requirements.	1 ✓ 2 5

F10 Decimal Point	Determines location of the decimal point.	0 √ 00 0.0000 0.000 0.00 0.0
F11 No. of L/C wires	Selects the number of wires on the load cell(s) to be connected to the indicator. Cabled systems only. "4" = four wires "6" = six wires (SENSE)	4 √ 6
F12 Enable lb-oz display	Allows you to enable or disable lb-oz display "1" = lb-oz is enabled "0" = lb-oz is disabled	0 √ 1
F14 Power-on zero (IZSM)	Allows you to enable or disable power-on zero. (IZSM); max is 20% of FS "1" = IZSM is enabled "0" = IZSM is disabled	0 √ 1
F15 Third unit selection	Allows you to choose (select) the third unit of measure "0" = third unit disabled "1" = grams (g) "2" = ounces (oz)	0 √ 1 2
F16 Zero Calibration	Places indicator into the zero-calibration routine. Scrolling down with the ZERO key one level begins the procedure.	Press ZERO key to begin sequence

CODE/NAME	DESCRIPTION	SELECTION LIST
F17 Span Calibration	Places indicator into the span calibration routine. Scrolling down with the ZERO key one level begins the procedure.	Press ZERO key to begin sequence
F18 View Calibration	Actuates the function that allows you to view both the zero and span calibration value. The values displayed in this function are valid only after Calibration (F16 & F17) has been successfully completed. Scrolling down with the ZERO key one level begins the procedure.	Press ZERO key to begin sequence
F19 Key-in Zero	Allows you to key-in known zero calibration value in case of memory loss in the field. Scrolling down with the ZERO key one level begins the procedure.	Press ZERO key to begin sequence
F20 Key-in Span	Allows you to key-in a known span calibration value in case of memory loss in the field. Scrolling down with the ZERO key one level begins the procedure.	Press ZERO key to begin sequence

F21 Factory Reset	This sub-menu will reset all parameters in the "F" and "A" menu to the default settings. It will not overwrite any previously saved calibration data. USE WITH CAUTION!	Press the ZERO key twice to execute
F23 Fine Tune 4-20 mA	Actuates the function that allows you to fine-tune the optional 4-20 mA analog output. Pressing the ZERO key to scroll down one level begins the sequence.	Press the ZERO key to begin sequence
F24 Analog Output Function	Selects the OPTIONAL active analog output function. "oFF" = Off "4-20 nnA " = 4-20 mA "0-10u " = 0-10V	oFF √ 4-20 nnA 0-10u
F25 Set Point Function	Selects the number of function of the set points and relay outputs. See user's guide for definitions	0 to 10 0 √
F26 Multi-interval segments	Selects the number of weighing segments for multi-interval. "0" = multi-interval is disabled	0 √ 1 2
F27 No. of Scale Divisions (WS1)	Selects the number of scale divisions to be used for Weighing Segment 1 (WS1). Scrolling down with the ZERO key one level begins the procedure.	Key-in 100 - 50000 1000 √
F28 No. of Scale Divisions (WS2)	Selects the number of scale divisions to be used for Weighing Segment 2 (WS2). Scrolling down with the ZERO key one level begins the procedure.	Key-in 100 - 50000 5000 √
F29 Load Cell Input	Selects the load cell input source. "AdC" = Internal A/D (cabled), "1rAdlo" = One external wireless A/D module, "2rAdlo" = Two external wireless A/D modules	AdC √ 1rAdlo 2rAdlo

CODE/NAME	DESCRIPTION	SELECTION LIST
F30 Special Application	Used to select one special application feature, subject to local legal requirements. "0" = None (Gross/Net)", "1" = Accumulation, "2" = Remote Display, "3" = Piece Count, "5" = Hold, "6" = Checkweigher	0 √ 1 2 3 5 6

<p>F31 Gross Zero Band</p>	<p>Selects the range within which the scale will automatically clear the tare and switch to Gross mode. Note that the scale must be in standstill. Selections are in display divisions (d). Scrolling down with the ZERO key one level begins the procedure.</p> <p>"0" = Disabled</p>	<p>Key-in 0 - 10 0 ✓</p>
<p>F32 Center of Zero Band</p>	<p>Selects the range around gross zero within which the scale will display the Center of Zero annunciator. Selections are in display divisions (d).</p>	<p>0.25 ✓ 0.5</p>
<p>F34 Auto Print Min. Weight</p>	<p>Selects the minimum weight at which the auto print function will work if enabled. Selections are in display divisions (d). Scrolling down with the ZERO key one level begins the procedure.</p> <p>"0" = Disabled</p>	<p>Key-in 0 - 100 1 ✓</p>
<p>F35 Hold Mode</p>	<p>This mode of operation is enabled by setting F30 to "5". This mode captures the weight of an unstable load, e.g. livestock, by freezing the weight on the display. Use the Motion Band setting (F5) and the Percentage Hold setting (F37) to adjust this mode to your specific application. When the weight has been locked onto the display, two arrows beneath the weight display will be turned ON.</p> <p>"0" = Off</p> <p>AUTOMATIC (F35 = 1) – Automatically locks weight on the display when stable. If the weight of the object on the scale changes by the F12 setting (e.g. 10%) then the sale unlocks the held reading and relocks onto the new weight. This occurs during both increasing and decreasing weight values.</p> <p>MANUAL (F35= 2) – Press the NET/GROSS key <u>before</u> applying any weight to the scale. After the load has stabilized, the display will hold the weight reading on the screen until the NET/GROSS key is pressed again. If the weight of the object on the scale changes by the F12 setting (e.g. 10%) then the sale unlocks the held reading and relocks onto the new weight. This occurs during increasing weight values only.</p> <p>PEAK HOLD (F35= 3) – The display updates as the load increases but not as the load decreases. The value shown on the screen is the maximum weight applied to the scale. Press the UNITS key to toggle between live mode and peak hold mode. The 'P' annunciator is used to indicate that you are in Peak Hold mode. When you exit out of peak hold mode, the old peak value is automatically cleared.</p>	<p>0 ✓ 1 2 3</p>

F36 Percentage Hold Weight	Allows you to select the percentage (of the displayed held value) of weight change before the scale automatically unlocks the held weight and relocks onto the new weight. If F35 is set to "0", this function does nothing.	Key-in 0 – 100 % 10 ✓
--------------------------------------	--	------------------------------------

CODE/NAME	DESCRIPTION	SELECTION LIST
F37 Min. Hold Weight	Sets the minimum weight that can be captured and held; expressed in display divisions (d). If F35 is set to "0", this function does nothing.	1, 2, 5 ✓, 10, 20, 50, 100, 200, 500, 1000
F41 FIR Window	Sets the Window Function of the FIR filter. "HAnnInG" = Hanning (Hann), "HA InG" = Hamming , "bIAC_" = Blackman	HAnnInG ✓ HA InG bIAC_
F42 FIR Type	Sets the FIR filter type. Choose this one first. "LPASS" = Low Pass, "HPASS" = High Pass, "bdPASS" = Band Pass	LPASS ✓ HPASS bdPASS
F43 FIR No. of Taps	Selects the number of taps (filter depth) of the FIR filter. The larger the number, the slower the response.	Key-in 1 - 99 29 ✓
F44 FIR Cutoff Frequency	Sets the cutoff frequency for both Low Pass and High Pass FIR types. Value must be less than or equal to one-half the F2 (sampling rate) setting.	Key-in 1 – F2 ÷ 2 5 ✓
F45 FIR Lower Cutoff Frequency	Sets the lower cutoff frequency for the Band Pass FIR type. Value must be less than or equal to one-half the F2 (sampling rate) setting.	Key-in 1 – F2 ÷ 2 1 ✓
F46 FIR Upper Cutoff Frequency	Sets the upper cutoff frequency for the Band Pass FIR type. Value must be greater than F45 setting.	Key-in 1 – F2 ÷ 2 2 ✓
F47 Post FIR Filter	Sets the post-FIR averaging filter. "0" = Disabled	0 1 2 3 ✓
F51 Auto Digital Filter - Max	Configures the Automatic digital filter (F6 = AUto). Maximum number of readings to be averaged. Choose the setting that works best for your application.	32 ✓, 64, 80, 96, 128

F52 Auto Digital Filter - Min	Configures the Automatic digital filter (F6 = AUto). Minimum number of readings to be averaged. Choose the setting that works best for your application.	1 √ , 8, 16, 24, 32
F53 Auto Digital Filter – Primary Band	Configures the Automatic digital filter (F6 = AUto). Primary band expressed in A/D counts. Choose the setting that works best for your application.	500 √ , 1000, 2000, 3000, 4000, 5000, 6000, 7000
F54 Auto Digital Filter – Secondary Band	Configures the Automatic digital filter (F6 = AUto). Secondary band expressed in A/D counts. Choose the setting that works best for your application.	0 √ , 10, 20, 50, 100, 150, 200, 250, 300

2.4 Entering the User/COM1 (“A1”) Menu

1. Press and hold the MENU/OFF key to switch off the digital indicator.
2. Press and hold the ON key until the digital indicator beeps and starts to boot up.
3. During the countdown phase (“555555, 444444”, etc.) press and hold the MENU/OFF key until the “Set?” message is displayed.
4. Press the NET/GROSS button while “Set?” is being displayed. The digital indicator displays “- F -”.
5. Press the PRINT (right) key once. The screen displays “-A1-”.
6. Scroll down using the ZERO (down) key to reach the parameter level. The digital indicator shows “A1-1”.
7. Move from one “A1” parameter to the next by using the TARE (left) or PRINT (right) keys. For example, to go from A1-1 to A1-2, press the PRINT key. To go from A1-2 back to A1-1, press the TARE key.
8. Once you have arrived at the proper “A1” menu parameter, e.g. “A1-1”, press the ZERO (down) key once to arrive at the selection level. The scale displays the current parameter setting.
9. If there is a selection list, scroll thru the available parameter settings, use the TARE (left) or PRINT (right) keys. Otherwise, use the arrow keys to adjust the displayed value to the new value.
10. Once the setting you want is displayed on the screen, press the NET/GROSS (set) key to save this value and revert up to the parameter level, e.g. “A1-1”.

2.5 User/COM1 ("A1") Menu Descriptions

This section provides more detailed descriptions of the selections found in the User Menu Chart. Factory-set defaults are shown in **bold** with a checkmark; (**√**).

CODE/NAM E	DESCRIPTION	SELECTION LIST
A1-1 Baud Rate	Selects the baud rate for data transmission through the serial port.	1200, 2400, 4800, 9600 √, 19200, 38400
A1-2 Data Bits, Parity and Stop Bits	Selects the number of data bits and parity of serial transmission. "8 n" = 8 data bits with no parity bit and one stop bit "7 o" = 7 data bits with odd parity bit and one stop bit "7 E" = 7 data bits with even parity bit and one stop bit "7 n" = 7 data bits with no parity bit and two stop bits	8 n √ 7 o 7 E 7 n

CODE/NAM E	DESCRIPTION	SELECTION LIST
A1-3 Serial Port Mode	Selects the mode of the serial port: Refer to Appendix B for more information. "0" = Demand Full Duplex "1" = Continuous Full Duplex "2" = Auto Print "4" = Test and Measurement	0 √ 1 2 4
A1-4 MP-20 Print Header	Tells MP-20 printer to print the header information. Valid only when Ax-6 is set to "2" or "4". "0" = Do NOT Print Header "1" = Print Header	0 √ 1
A1-5 Units Key	Selects function of the Units key. "0" = Disabled "1" = Enabled	0 1 √
A1-6 Output String	Selects fixed output string for serial port. Refer to Appendix B for details. Left off here "0" = String Format 1 (Condec Demand) "1" = String Format 2 (Condec Continuous) "2" = Text Print Ticket "3" = Text Print Ticket with MP-20 Auto Label Feed	0 1 2 √ 3
A1-7 ID Number	Selects the ID number mode. "0" = Disabled "1" = Enabled	0 √ 1

A1-8 Set ID Number	Allows you to key-in the ID number. Pressing the ZERO key to scroll down one level begins the sequence.	Key-in 0 to 999999 123456 ✓
A1-9 Line Feeds	Allows you to key-in the number of line feeds. Pressing the ZERO key to scroll down one level begins the sequence.	Key-in 0 to 99 8 ✓
A1-10 Auto Power Off	Allows you to configure the automatic power off time for the 8000 REPEL digital indicator. Expressed in minutes of in-activity (keys and weighing platform). Pressing the ZERO key to scroll down one level begins the sequence.	Key-in 0 to 30 0 ✓ (always on)
A1-11 Backlight Behavior	Allows you to configure the behavior of the LCD back-light for the 8000 REPEL digital indicator. "oFF" = Always off "on" = Always on "AUto" = Automatic operation	oFF on ✓ AUto
A1-12-1 Backlight Color - Normal	Selects the color of the LCD (liquid crystal display) in normal operating mode. "1" = Green, "2" = Blue, "3" = R + G + B, "4" = R + G, "5" = R + B, "6" = G + B	1 ✓ 2 3 4 5 6
A1-12-2 Backlight Color - Hold	Selects the color of the LCD (liquid crystal display) when the weight is locked onto the screen in Hold mode. "1" = Green, "2" = Blue, "3" = R + G + B, "4" = R + G, "5" = R + B, "6" = G + B	1 2 3 ✓ 4 5 6

CODE/NAM E	DESCRIPTION	SELECTION LIST
A1-13 Handshaking	Selects function of the hardware handshaking. (NOTE: Receive pin is used for handshaking). "0" = Disabled "1" = Enabled	0 ✓ 1
A1-18 Date & Time Print	Selects function of the printed date and time. "0" = Disabled "1" = Enabled	0 ✓ 1
A1-20 Set System Time & Date	Allows you to set the system time and date. Pressing the ZERO key to scroll down one level begins the sequence.	Press ZERO key to begin sequence

A1-23 Audible Key Feedback	Selects function of the audible key feedback (beeper). "0" = Disabled "1" = Enabled	0 1 ✓
A1-24 Diagnostics	Used to access the listed test functions (one at a time). Pressing the ZERO key begins the sequence. "A1-24-1" = Display segment test, "A1-24-2" = A/D converter test, "A1-24-5" = Serial Port test (both), "A1-24-6" = Keyboard test	Press ZERO key to begin sequence
A1-25 Output Logic	Use this menu to assign the active logic level to each of the optional digital output terminals (OUT1 thru OUT3). "0" = Low logic, "1" = High logic	0 1 ✓
A1-26-1 Low Battery Detection	Select low battery detection mode. "0" = Disabled "1" = Enabled	0 ✓ 1
A1-26-2 No. of Batteries	Selects the number of rechargeable batteries. "b2 – 7.4" = 3.7V x 2 batteries (7.4V) "b4 – 14.8" = 3.7V x 4 batteries (14.8V)	b2 – 7.4 ✓ b4 – 14.8
A1-26-3 Battery Count - Read	Allows you to read the battery count. Pressing the ZERO key to scroll down one level begins the sequence.	Press ZERO key to begin sequence
A1-26-4 Battery Count - Edit	Allows you to edit the battery count. Pressing the ZERO key to scroll down one level begins the sequence.	Press ZERO key to begin sequence
A1-26-5 Battery Count - Reset	Allows you to reset the battery count. Pressing the ZERO key to scroll down one level begins the sequence.	Press ZERO key to begin sequence

2.6 Setting system time and date (A1-20)

1. Press and hold the MENU/OFF key to switch off the digital indicator.
2. Press and hold the ON key until the digital indicator beeps and starts to boot up.
3. During the countdown phase ("555555, 444444", etc.) press and hold the MENU/OFF key until the "Set?" message is displayed.

4. Press the NET/GROSS button while "Set?" is being displayed. The digital indicator displays "- F -".
5. Press the PRINT (right) key once. The screen displays "-A-".
6. Scroll down using the ZERO (down) key to reach the parameter level. The scale shows "A1-1".
7. Move from A1-1 to A1-20 by pressing the TARE (left) key repeatedly until the screen shows "A1-20".
8. Once you have arrived at A1-20 press the ZERO (down) key once. The screen displays "ho_xx" where 'xx' is the current hour, e.g. "15". One digit will be flashing.
9. Use the four directional keys to adjust the displayed value to the actual hour value. Increase the flashing digit by pressing the UNITS key. Decrease the flashing digit by pressing the ZERO key. Pressing the TARE key or the PRINT key will change the position of the flashing digit.
10. After entering the exact value, press the NET/GROSS key to save the value. The screen displays "n~_xx" where 'xx' is the current minute, e.g. "55". One digit will be flashing.
11. Use the four directional keys to adjust the displayed value to the actual minute value. Increase the flashing digit by pressing the UNITS key. Decrease the flashing digit by pressing the ZERO key. Pressing the TARE key or the PRINT key will change the position of the flashing digit.
12. After entering the exact value, press the NET/GROSS key to save the value. The screen displays "dA_xx" where 'xx' is the current day of the month, e.g. "14". One digit will be flashing.
13. Use the four directional keys to adjust the displayed value to the actual day value. Increase the flashing digit by pressing the UNITS key. Decrease the flashing digit by pressing the ZERO key. Pressing the TARE key or the PRINT key will change the position of the flashing digit.
14. After entering the exact value, press the NET/GROSS key to save the value. The screen displays "n~_xx" where 'xx' is the current month of the year, e.g. "02". One digit will be flashing.
15. Use the four directional keys to adjust the displayed value to the actual month value. Increase the flashing digit by pressing the UNITS key. Decrease the flashing digit by pressing the ZERO key. Pressing the TARE key or the PRINT key will change the position of the flashing digit.
16. After entering the exact value, press the NET/GROSS key to save the value. The screen displays "yE_xx" where 'xx' is the current month of the year, e.g. "11". One digit will be flashing.

17. Use the four directional keys to adjust the displayed value to the actual year value. Increase the flashing digit by pressing the UNITS key. Decrease the flashing digit by pressing the ZERO key. Pressing the TARE key or the PRINT key will change the position of the flashing digit.
18. After entering the exact value, press the NET/GROSS key to save the value and revert up to the parameter level, e.g. "A1-20".

2.7 Diagnostics (A1-24)

Here is a brief description of each test mode:

A1-24-1 Display Test – Lights up all display segments. End test manually by pressing the NET/GROSS (Set) key.

A1-24-2 ADC Test – Shows internal A/D converter counts – useful for troubleshooting weighing issues. End test manually by pressing the NET/GROSS (Set) key. The Zero key works in this mode.

A1-24-5 Serial Test – Transmits a data string continuously out both serial ports ("TEST1" on COM1 and "TEST2" on COM2). End test manually by pressing the NET/GROSS (Set) key.

A1-24-6 Keyboard Test – Displays a keycode for each key pressed on the keypad. See Table below. End test manually by pressing the NET/GROSS (Set) key.

Key	Keycode
Units	1
Zero	2
Net/Gross	EXIT
Tare	4
Print	5

2.8 Entering the COM2 ("A2") Menu

1. Press and hold the MENU/OFF key to switch off the digital indicator.
2. Press and hold the ON key until the digital indicator beeps and starts to boot up.
3. During the countdown phase ("555555, 444444", etc.) press and hold the MENU/OFF key until the "Set?" message is displayed.
4. Press the NET/GROSS button while "Set?" is being displayed. The digital indicator displays "- F -".
5. Press the PRINT (right) key twice. The screen displays "-A2-".
6. Scroll down using the ZERO (down) key to reach the parameter level. The scale shows "A2-1".

7. Move from one "A2" parameter to the next by using the TARE (left) or PRINT (right) keys. For example, to go from A2-1 to A2-2, press the PRINT key. To go from A2-2 back to A2-1, press the TARE key.
8. Once you have arrived at the proper "A2" menu parameter, e.g. "A2-1", press the ZERO (down) key once to arrive at the selection level. The scale displays the current parameter setting.
9. If there is a selection list, scroll thru the available parameter settings, use the TARE (left) or PRINT (right) keys. Otherwise, use the arrow keys to adjust the displayed value to the new value.
10. Once the setting you want is displayed on the screen, press the NET/GROSS (set) key to save this value and revert up to the parameter level, e.g. "A2-1".

2.9 COM2 ("A2") Menu Descriptions

This section provides more detailed descriptions of the selections found in the User Menu Chart. Factory-set defaults are shown in **bold** with a checkmark; (✓).

CODE/NAME	DESCRIPTION	SELECTION LIST
A2-1 Baud Rate	Selects the baud rate for data transmission through the serial port.	1200, 2400, 4800, 9600 ✓, 19200, 38400
A2-2 Data Bits, Parity and Stop Bits	Selects the number of data bits and parity of serial transmission. "8 n" = 8 data bits with no parity bit and one stop bit "7 o" = 7 data bits with odd parity bit and one stop bit "7 E" = 7 data bits with even parity bit and one stop bit "7 n" = 7 data bits with no parity bit and two stop bits	8 n ✓ 7 o 7 E 7 n
A2-3 Serial Port Mode	Selects the mode of the serial port: Refer to Appendix B for more information. "0" = Demand Full Duplex "1" = Continuous Full Duplex "2" = Auto Print "3" = RFID "4" = Test and Measurement	0 ✓ 1 2 3 4
A2-4 MP-20 Print Header	Tells MP-20 printer to print the header information. Valid only when Ax-6 is set to "2" or "4". "0" = Do NOT Print Header "1" = Print Header	0 ✓ 1

A2-6 Output String	Selects fixed output string for serial port. Refer to Appendix B for details. Left off here "0" = String Format 1 (Condec Demand) "1" = String Format 2 (Condec Continuous) "2" = Text Print Ticket "3" = Text Print Ticket with MP-20 Auto Label Feed	0 1 2 ✓ 3
A2-9 Line Feeds	Allows you to key-in the number of line feeds. Pressing the ZERO key to scroll down one level begins the sequence.	Key-in 0 to 99 8 ✓
A2-13 Handshaking	Selects function of the hardware handshaking. (NOTE: Receive pin is used for handshaking). "0" = Disabled "1" = Enabled	0 ✓ 1

3 SYSTEM CALIBRATION

3.1 Calibration Overview

Digital system calibration is accomplished in two steps: zero calibration (F16) and span calibration (F17). You may restore factory calibration values via the B6 menu. In the unlikely event that any calibration value is lost, the setup menu makes provisions for re-entering these values via F19 and F20; eliminating the need for re-calibration with test weights.

For dual wireless A/D modules systems (e.g. TI-500 RFTM-2BE), a digital corner calibration feature is also available. It does not require a specific test weight value, but the maximum weight that should be used is approximately 25% of the rated capacity of the platform.

NOTE: Please perform corner calibration prior to executing zero/span calibration.

3.2 Digital Zero/Span Calibration (F16 and F17)

1. Press and hold the MENU/OFF key to switch off the digital indicator.
2. Press and hold the ON key until the digital indicator beeps and starts to boot up.
3. During the countdown phase ("555555, 444444", etc.) press and hold the MENU/OFF key until the "Set?" message is displayed.
4. Press the NET/GROSS button while "Set?" is being displayed. The digital indicator displays "- F -".
5. Scroll down once using the ZERO key to enter the "Setup" menu. Scale shows "F 1".

6. While in the Setup mode, scroll to "F 16", and then scroll down once using the ZERO key to enter zero calibration menu. The display will momentarily show "C 0" followed by a value. This value is the internal A/D count and can prove useful when trying to troubleshoot setup problems.
7. Remove all items from the weighing platform and press the ZERO key to zero out the displayed value.
8. Press the NET/GROSS key to save the zero-point value. The display will show "EndC0" momentarily, and then revert up to F16.
9. Press the PRINT key to progress to the F17 menu.
10. While at the "F 17" screen, scroll down once using the ZERO key to enter span calibration menu. The display will momentarily show "C 1" for the span calibration point, followed by a value with one flashing digit.
11. Place the test weight on the weighing platform.
12. Use the four directional keys to adjust the displayed value to the actual test weight value. Increase the flashing digit by pressing the UNITS key. Decrease the flashing digit by pressing the ZERO key. Pressing the TARE key or the PRINT key will change the position of the flashing digit.
13. After entering the exact value, press the NET/GROSS key to save the value. If the calibration was successful, the display will show "EndC1" momentarily, followed by "C 2" for the second calibration point.
14. If using multi-point calibration, repeat steps 10-11 for C2 and C3. **Otherwise, enter a zero value in for C2.** At the conclusion of this step, the indicator displays the current gravity settings, e.g. "9.800".
15. If the local gravity factor is known, then use the up/down and left/right keys to adjust the displayed value. Otherwise, just press the NET/GROSS key. The display will show "-donE".
16. Press the NET/GROSS key to revert up to "F17".
17. If the calibration was *not* successful, one of the error messages below will appear. Take the indicated action to correct the problem, and then perform a new calibration.
 - "Err0" - The calibration test weight or the keyed-in weight is larger than the full capacity of the scale. Change the calibration test weight or check the input data.
 - "Err1" - The calibration test weight or the keyed-in weight is smaller than 1% of the full capacity of the scale. Change the calibration test weight or check the input data.
 - "Err2" – There is not enough signal from the load cells to establish a proper calibration. Most common causes include incorrect load cell wiring, a mechanical obstruction or a faulty (damaged) load cell.

3.3 Key-In Zero Calibration Value (F19)

Note: This procedure is intended for emergency use only in the case of non-volatile memory loss. A valid zero calibration value, obtained from a successful F16 calibration procedure, must be used.

1. While in the Setup mode, scroll to "**F 19**", and then scroll down once using the ZERO key. The display will momentarily show "**C 0**", followed by a value.
2. Use the four directional keys to enter in the actual zero calibration value.
3. After entering the exact value, press the NET/GROSS key to save the value. The display will revert up to F19.

3.4 Key-In Span Calibration Value (F20)

Note: This procedure is intended for emergency use only in the case of non-volatile memory loss, but it can also be used to manually linearize your scale. Valid span calibration values, obtained from a successful F17 calibration procedure, must be used.

1. While in the Setup mode, scroll to "**F 20**", and then scroll down once using the ZERO key. The indicator will prompt you to enter the information in the Table following.
2. If the value shown is correct, press the NET/GROSS key to move to the next parameter. Otherwise, use the four directional keys to enter in the actual calibration value
3. After setting the exact value, press the NET/GROSS key to save the value.
4. At the completion of the sequence, the indicator will then revert up to F20.

CODE	NAME
t 1	First Test Weight Value
C 1	First Span Calibration Value
t 2	Second Test Weight Value
C 2	Second Span Calibration Value
t 3	Third Test Weight Value
C 3	Third Span Calibration Value

Calibration Value Entry Table
Balance of page intentionally left blank

4 SERIAL PORT INFO

4.1 Serial Port Modes

DEMAND DUPLEX MODE

The Demand Duplex Mode provides a two-way serial transmission mode. In this mode, the output information is transmitted on demand; either by pressing the PRINT key on the indicator's front panel or upon receiving a recognized command from a host device (i.e. computer).

NOTE: Ensure that your cabling contains the proper handshaking.

CONTINUOUS DUPLEX MODE

The Continuous Duplex Mode provides a two-way serial transmission mode. In this mode, the output information is transmitted continuously making it a popular choice for remote displays and other remote devices requiring a constant data stream. The transmission automatically occurs at the end of each display update. The indicator will react upon receiving a recognized command from a host device.

RECOGNIZED HOST COMMANDS (applies to both demand and continuous duplex modes)

- "P"** - This command is sent to the indicator to print the indicated display. The indicator will not respond if the scale is in motion, positive overload or negative overload.
- "Z"** - This command is sent to the indicator to zero the scale. The indicator will not respond if the scale is in motion, positive overload or negative overload. The indicator will also not respond if it is not in gross mode or within the zero-range specified in F4 of the Setup Menu.
- "T"** - This command is sent to the indicator to tare the scale. The indicator will not respond if the scale is in motion, positive overload or negative overload. The indicator will also not respond if it is displaying a negative gross value.
- "G"** - This command is sent to the indicator to switch to gross mode. The indicator will not respond if the scale is in motion, positive overload or negative overload.
- "N"** - This command is sent to the indicator to revert to net. The indicator will not respond if the scale is in motion, positive overload or negative overload. The indicator will also not respond if a tare has yet to be established.
- "C"** - This command is sent to the indicator to toggle among the configured units of measure.

AUTO PRINT MODE

The Auto Print Mode provides a one-time serial transmission once a non-zero, stable condition is achieved.

TEST AND MEASUREMENT MODE

The Test and Measurement Mode is identical to the Demand Duplex Mode with one exception: the indicator will respond to a PRINT command even when the scale is in motion, positive overload or negative overload.

4.2 Output Strings

TEXT PRINT TICKET

The Text Print Ticket is designed specifically for a serial printer.

ID. NO.	123456
GROSS	25.00 lb
TARE	1.48 lb
NET	23.52 lb
DATE	03/01/2011

NOTES:

- 1.The TARE and NET fields are not printed unless a tare has been established in the system.
- 2.The ID number field is not printed if it is disabled in A7 of the User Menu.
- 3.The date is not printed if it is disabled in A18 of the User Menu.

STRING FORMAT 1 (Condec Demand String)

String Format 1 is designed for two-way communication.

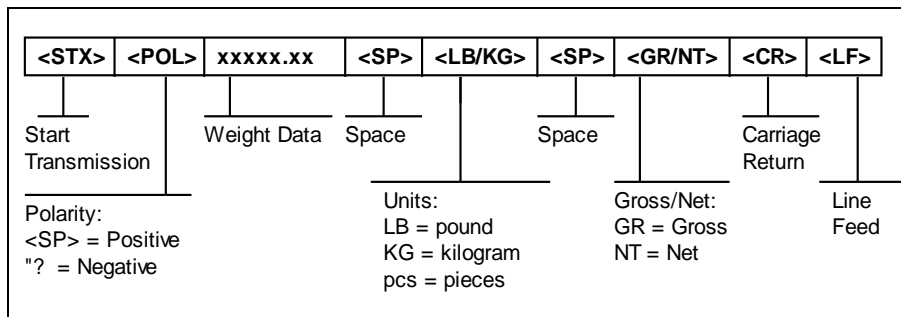

STRING FORMAT 2 (Condec Continuous String)

String Format 1 is designed for one-way communication.

