

# 8400 VERSA INDICATOR



8400 VERSA PANEL MOUNT

## FEATURES

- Large multi-segment display that uses logical prompts along with dedicated and programmable function keys
- Primary display is 29mm (1.1") and secondary display 18mm (0.7").
- Printing can be tailored with custom record, docket or reports printouts
- Rugged load cell input - designed to take 16x320 ohm load cells
- Support for both Ethernet and Profibus DP to improve integration into larger control systems
- Use the menu system directly via the alpha numeric keypad or the configuration utility View400 on a PC
- Covers a wide range of applications
- The modular design allows for the installation to be commissioned with only the components required, saving on time and money
- English, Spanish, German, Dutch, French, Polish and Italian operator languages
- Programmable *f* keys to program your most used functions
- Print, Single, Test, Count, Piece, Units, Hold, Peak Hold, Product Select, High Resolution, Semi-automatic Preset Tare are all functions that can be programmed on the function keys

## ACCESSORIES

- Thermal Ticket Printer
- Label Printer
- Remote Display
- Indicator Stand

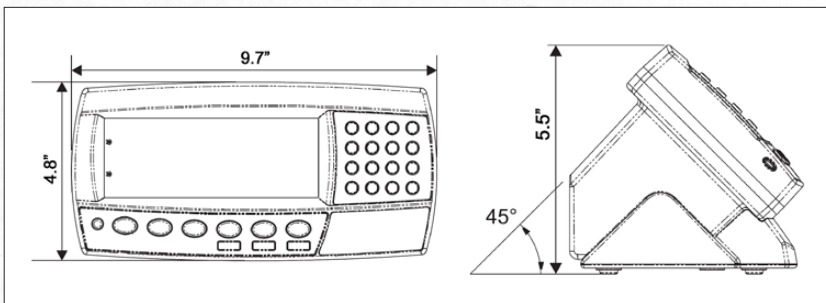

## SPECIFICATIONS

### DISPLAY:

LCD with a 1.1" primary display and a 0.7" secondary display

### UNITS:

lb, kg, t

### ACCURACY CLASS:

III NTEP 08-720

### RESOLUTION:

Up to 100,000 d, minimum of 0.25uV/d

### ZERO RANGE:

+/- 2% to +/- 20% of full capacity

### A/D TYPE:

24bit Sigma Delta

### LOAD CELL:

16 load cells of 350 Ω maximum

### SENSITIVITY (INTERNAL):

0.3 μV/d

### INPUT VOLTAGE:

110/240VAC 50/60Hz

### POWER:

12-24VDC (15 VA max)

### BATTERY:

Rechargeable NiHM, 12V, 2.5Ah

### OPERATING TEMPERATURE:

14°F to 122°F ≤ 90%RH

### DECIMAL POINTS:

Selectable 0, 1, 2, 3, 4 decimal places

### INTERFACE:

RS232, RS-485

### BAUD RATE:

2400/4800/9600/19200

### APPROVALS:

NTEP, FCC, CE, C-tick

MODEL	DISPLAY	MATERIAL	IP	SHIP WT.
8400 Versa	LCD	ABS	IP66	7 lbs